

# Little GIANT<sup>®</sup>

## Pump Company

### 3E-34N SERIES



#### Features

- For submersed or in-line use
- Epoxy coated die-cast aluminum housing
- Oil-filled motor
- 20.3' maximum lift
- 208 watts
- 1/2" MNPT discharge
- Thermal overload protection

#### Construction

- Motor — 1/15 HP Oil-filled
- Intermittent Liquid Temp. up to — 120° F
- Intake — 3/4" FNPT
- Discharge — 1/2" MNPT
- Housing — Epoxy coated cast aluminum
- Cover — Epoxy coated cast aluminum
- Volute — Nylon
- Impeller — Nylon
- Shaft Seal — Viton<sup>®</sup>
- Screen — Polypropylene

Dual purpose oil-filled pump that may be used totally submersed or in-line (fed with pipe or hose). For commercial, industrial and home applications including statuary fountains, water displays, air conditioners, machine tool coolants, and many other applications where liquid must be transferred or recirculated. This compact 670 GPH pump features a 1/2" MNPT discharge and 20.3' shut-off head capability.

# Little Giant Pump Co.

## 3E-34N SERIES

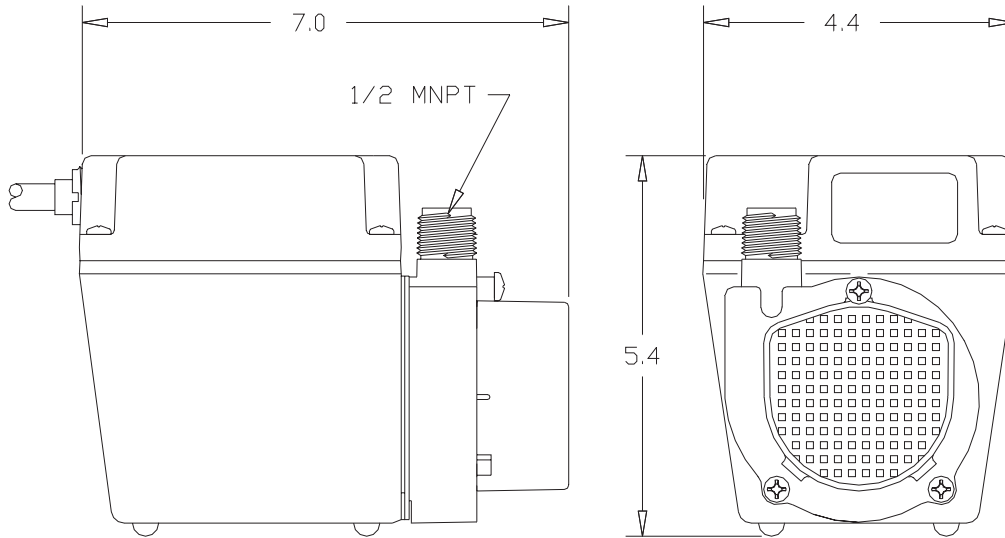

### Specifications

Model No.	Item No.	Discharge	Intake	Listing(s)	HP	Volts	Hertz	Amps	Watts	Performance (GPH @ Head)				Shut Off		Pwr. Cord (ft)	Weight (Lbs.)
										1'	3'	5'	10'	Feet	PSI		
3E-34N	503603	1/2" MNPT	3/4" FNPT	UL/CSA	1/15	115	60	3.2	200	670	650	575	460	20.3	8.8	10	8.25

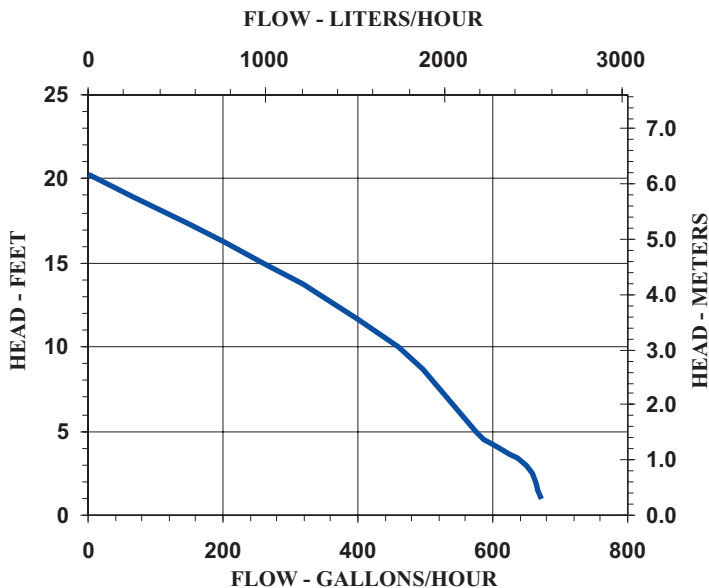

### Replacement Parts

Volute	102334
Impeller	103437
Screen	103601
Gasket	102909

**Little Giant Pump Co.**  
 PO Box 12010  
 Okla. City, OK 73157  
 Phone: 405.947.2511  
 Fax: 405.228.1550  
[www.LittleGiantPump.com](http://www.LittleGiantPump.com)